

NOTES AND COMMENTS

PREPARATION OF SMALL SAMPLES FOR ^{14}C ACCELERATOR TARGETS BY CATALYTIC REDUCTION OF CO

P J SLOTA, JR

Radiocarbon Laboratory, Department of Anthropology, University of California, Riverside, California 92521

A J T JULL, T W LINICK, and L J TOOLIN

NSF Accelerator Facility for Radioisotope Analysis
University of Arizona, Tucson, Arizona 85721

Graphite in various forms has become the standard target for accelerator ^{14}C dating. Graphite has been made by catalytic graphitization of charcoals (Lowe, 1984). Thin films of graphite have also been produced by thermal cracking (Beukens & Lee, 1981), electric discharge (Andrée *et al.*, 1984; Wand, Gillespie & Hedges, 1984). Vogel *et al.* (1984) pointed out the ease of graphite formation on iron from CO_2 and H_2 mixtures at ca 600°C. The deposition reactions of carbon from the CO , H_2 , and CO_2 equilibria are well known (Wagman *et al.*, 1945) and well studied. Formation of graphite from CO_2 was discussed extensively by Boudouard (1902) and Schenck and Zimmerman (1903), and was known to chemists in France in 1851. We have used a related method, where graphite forms away from the iron, by using a higher temperature, and reduction of CO_2 to CO over Zn in the presence of H_2 (Jull *et al.*, 1986) as an alternative to the use of Fe alone. The object of this paper is to point out an even simpler graphite preparation system, which eliminates hydrogen. The decomposition reaction of CO (Boudouard, 1902) takes place according to reaction (1).



If carbon is introduced as CO_2 , and is reduced to CO by hot Zn and any CO_2 formed due to reaction (1) is reduced to CO by the hot Zn, then the reaction proceeds in one direction. This method uses a small-volume system, which can be of any size but is typically 5 to 10cc. Using a 5cc system, reduction of CO samples of as small as 0.7cc has been achieved. The apparatus is shown in Figure 1. As mentioned, two reactions occur in the system. CO_2 is reduced to CO over ~30mg Zn at ca 500°C, and the CO disproportionates to graphite over the iron (~1mg) at typically 700°C. Deposition occurs at temperatures as low as 450°C. The graphite is separate from the iron, suggesting a vapor-phase intermediate.

The gas pressure is monitored, and 100% reaction is easily observable, as we wait until the gas pressure is zero. This takes from 2 to 10 hours, depending on several factors. It is clear that the reaction is pressure- and temperature-dependent; however, variations in reaction rate appear to be complex, and apparently dependent on the catalyst. The amount of Fe catalyst used can be very small (<1mg) without measurable effect on the reac-

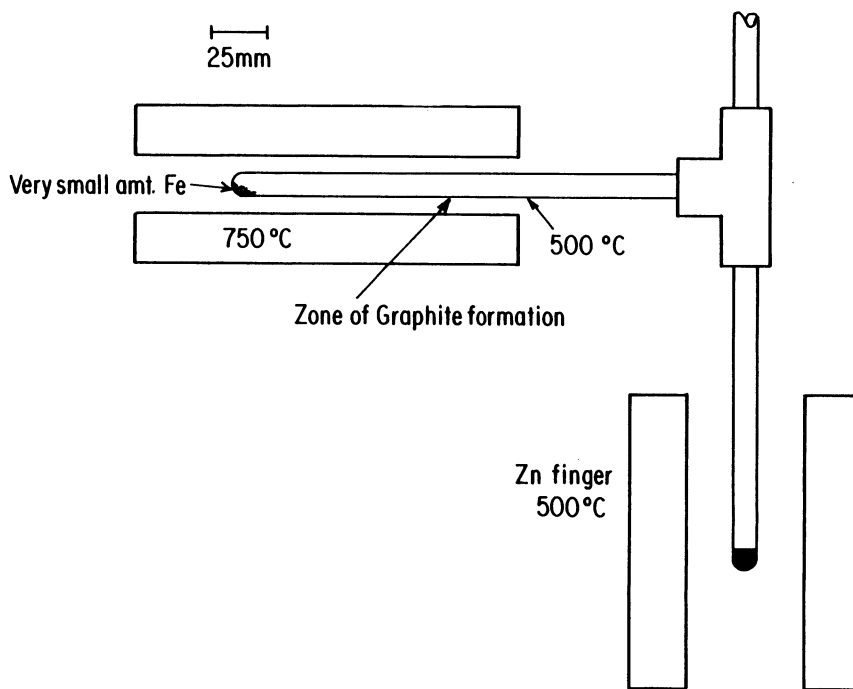

Fig 1. Diagram of small reduction line for graphite production. The horizontal tube contains 1mg iron catalyst; the vertical tube, 30–60mg zinc.

tion rate. In general, pressures approaching one atmosphere result in a complete reaction in 2 to 4 hours. We have also experimented with a small, sealed tube reduction at the University of California, Riverside, using Fe and Zn in the same tube. The graphite produced appears to be equivalent to the graphites made in the above apparatus (Slota & Taylor, 1986).

The graphite powder is collected, weighed, and ca ~ 1 mg (if available) is pressed into a standard target holder for accelerator ^{14}C analysis. A diagram of the press arrangement is shown in Figure 2. Samples as small as 0.3mg have been successfully analyzed. A series of pressed graphites from this procedure have been studied for $^{12}\text{C}^-$ beam current. Results of an initial series of 45 targets gave a mean current of $4.2\mu\text{A}$, lower than observed previously ($7\mu\text{A}$) by Jull *et al* (1986). However, modification of the press arrangement to incorporate an Al plug behind the graphite lead to better pressure transfer to the graphite. C^- currents are now ca $10\mu\text{A}$. Blanks are $0.35 \pm 0.15\%$ modern C, giving a 2σ age limit of $>46,000$ yr BP.

X-ray diffraction, $^{12}\text{C}^-$, and isotopic fractionation data show that the CO-produced graphite has similar characteristics to graphite produced from CO/ H_2 mixtures (Jull *et al*, 1986). ^{14}C dates run using these graphites have produced precisions of better than $\pm 1\%$ in $^{14}\text{C}/^{13}\text{C}$ ratio (in 50 min measuring time), and our best data are now approaching ± 50 ^{14}C years. We plan to report more fully on our techniques and on accuracy and precision

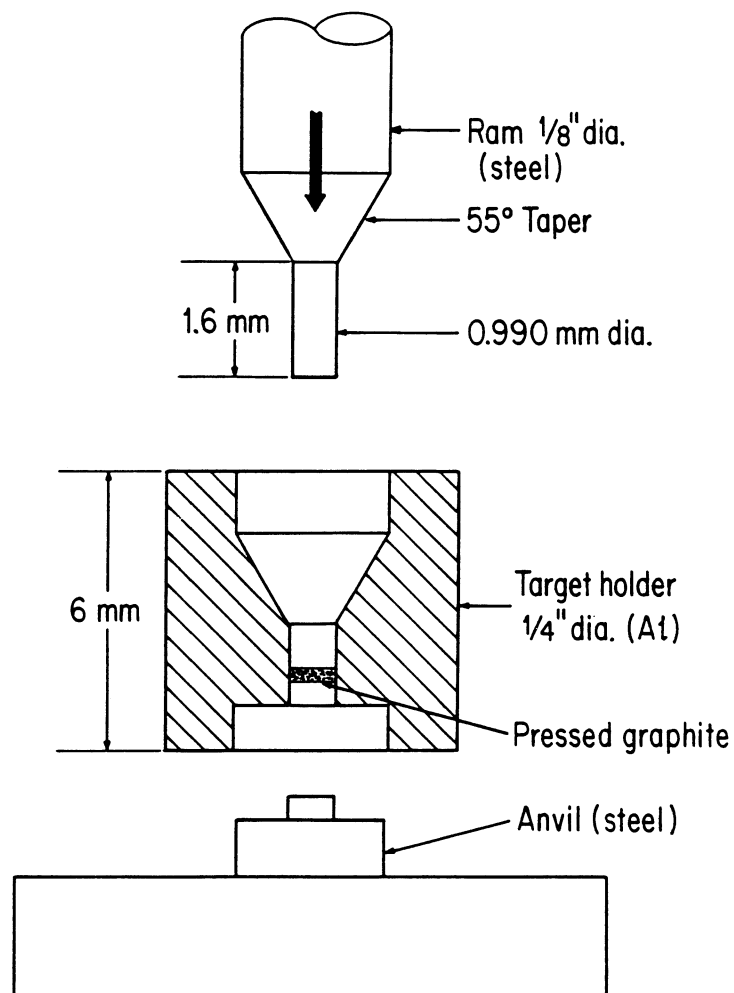

Fig 2. Target press arrangement

in the near future; the purpose of this note is to point out an extremely simple graphite preparation method without the need for hydrogen as a reducing agent.

ACKNOWLEDGMENT

This research was funded by the NSF accelerator grant, EAR-8309448, and BNS-8211804 and 8408192 (Anthropology Program) to R E Taylor.

REFERENCES

- Andrée, M, Beer, J, Oeschger, H, Bonani, G, Hofmann, H J, Morenzoni, E, Nessi, M, Suter, M and Wölfli, W, 1984, Target preparation for milligram-sized ^{14}C samples and data evaluation for AMS measurements: *Nuclear Instruments & Methods*, v 223, no. B5, p 274–279.
- Beukens, R P and Lee, H W, 1981, The production of small carbon samples by R F dissociation of acetylene, *in* Kutschera, W, ed, *Symposium on Accelerator Mass Spectrometry*, 2nd, Proc: Argonne Natl Lab, p 416–425.
- Boudouard, O, 1902, Recherches sur les équilibres chimiques: *Ann Chim Phys*, v 24, ser 7, p 5–85.
- Jull, A J T, Donahue, D J, Hatheway, A L, Linick, T W and Toolin, L J, 1986, Production of graphite targets by deposition from CO/H_2 for precision accelerator ^{14}C measurements, *in* Stuiver, M and Kra, R S, eds, *Internatl ^{14}C conf*, 12th, Proc: Radiocarbon, v 28, no 2A, p 191–197.
- Lowe, D C, 1984, Preparation of graphite targets for radiocarbon dating by tandem accelerator mass spectrometry: *Internatl Jour Applied Radiation Isotopes*, v 35, p 349–352.
- Schenck, R and Zimmerman, F, 1903, Ueber die Spaltung des Kohlenoxyds und das Hochofengleichgewicht: *Berichte deutschen chem Gesellschaft*, v 36, p 1231–1235.
- Slota, P J, Jr and Taylor, R E, 1986, AMS ^{14}C analysis of samples from archaeological contexts: pretreatment and target preparation, *in* University of California AMS conf Proc: Livermore, Inst Geophysics Planetary Physics.
- Vogel, J S, Southen, J R, Nelson, D E and Brown, T A, 1984, Performance of catalytically condensed carbon for use in accelerator mass spectrometry: *Nuclear Instruments & Methods*, v 223, no. B5, p 289–293.
- Wagman, D D, Kilpatrick, J E, Taylor, W J, Pitzer, K S and Rossini, F D, 1945, Heats, free energies and equilibrium constants of some reactions involving D_2 , H_2 , H_2O , C, CO, CO_2 and CH_4 : *Jour Research Natl Bur Standards*, v 34, p 143–161.
- Wand, J O, Gillespie, R and Hedges, R E M, 1984, Sample preparation for accelerator-based radiocarbon dating: *Jour Archaeol Sci*, v 11, p 159–163.